



## USERS MANUAL KOP3 Battery Chargers

KOP3 battery chargers are modern fully automatic devices suitable not only for charging but also for maintaining and monitoring the batteries. The charger stores data about charging times and Ah charged. This data may be accessed for further analysis. The device is protected against reverse polarity and short circuit, has adjustable time limitations for every charging phase, battery temperature monitoring and compensation and current reduction at elevated ambient temperatures.

Your battery charger was factory programmed for a specific battery type. Make sure the charging profile suits your battery type. To change the charging profile for a specific battery type, parameters can only be programmed with a PC software package and a programming interface. The programming parameters allow the charger's profile to suit the battery type. Up to five charging phases can be programmed with separate values for charging voltages, currents, charging times, temperature compensation and other control functions. Please contact your dealer for further information. When programming the charging profile always follow the battery manufacturer's recommendations.

**Please read the operating and safety instructions carefully before using or installing the KOP3 battery charger!**

### START OF THE CHARGING PROCESS

Establish a safe connection between the battery and the charger first. Then plug the mains connector. When removing the connection, remove the mains plug from the mains first, before disconnecting the battery.

The charger type is shown first after the charger has been connected to the mains and then the measured values as the battery voltage – see the following page.

The charging time depends on battery size and state of charge. If the battery was only slightly loaded, then the charging process will complete faster. At higher ambient temperatures or when exposed to strong sunlight, the charging current is reduced and the charging time increased accordingly. The charger can remain connected to the battery permanently. The power consumption is less than 0.5 mA.

The pictures below illustrate the values shown by the charger display.

<p>Main screen</p>	<p>In the first row the battery voltage and the battery current are shown. The battery voltage indicates the voltage at the battery terminals and not the output voltage of the charger. This value is exact only if the voltage drop compensation parameter has been set correctly.</p> <p>The charging current may be smaller as the charger nominal value if a lower value has been programmed or if the charging power or the mains current are at their limits or if cooling is insufficient and the overheating protection is active.</p>
<p>Secondary screen</p>	<p>The Symbol  after the displayed number shows that the corresponding value has reached the limit.</p> <p>In the bottom line is the info icon . By pressing on the info it can be switched between the three screens (see the pictures on the left side).</p> <p>The bottom row shows the current charging phase on the left and the total charging time in hours and minutes on the right side.</p>
<p>Info screen</p>	<p>The abbreviation <b>SN</b> is for serial number of the charger. <b>Firmware</b> and <b>Revision</b> show the version and revision of charger firmware in the left column and of display firmware in the right column.</p> <p>Touching of the English or German national flag switches between the languages for displaying warnings and error messages.</p>
<p>The current and voltage values depend on battery state of charge, on charger parameters (up to five charging phases can be set), environment temperature, mains voltage and battery temperature if temperature compensation has been enabled with charger parameters. If the charging current is lower than the parameter value for one of these reasons, then the charging time is increased accordingly.</p> <p>Meanings of other displayed values are shown in the table on the following page.</p>	

## Meanings of the values shown on the display

Batt. temp.	Battery temperature in °C This value is displayed if the temperature sensor is connected. When the battery temperature monitoring and battery temperature compensation have been unlocked with the charger parameters, then the measured value is also checked for validity.
Charg. temp.	Internal temperature of the charger power stage in °C
Charge	The charged Ah (Ampere-hours) After the completion of charging the value of the charged Ah is displayed until a new battery is connected or charging is restarted for the same battery.
BMS	If a battery management system is connected then it's request for current reduction (percentage of nominal current) is shown.
Iac	Line current (current from the mains socket) This current is limited to 14,8A by charger firmware. It can be higher as 14,8A during fast load or mains changes only.
Power	Charging power in W = Charging current x Battery voltage The power output (total power) of the charger is not the same as the charging power. It also includes losses at the cables, fuses and plugs. The voltage drops are compensated by the charger. The charger output power limit includes losses of the various voltage drops. Therefore, the maximum achievable charging power can be somewhat smaller than 3000W in practice since the total charger output is limited to 3000W and not the battery charging power. A charging power of less than 3000W can also be caused by a low supply voltage (limit of the line current).
U comp.	Compensation of the charging voltage in V This value indicates for how much the voltage measured inside of the charger is higher than the voltage at the battery terminals.
Phase	The current charging phase After the charging has been completed and the charger has turned off the text "END" text appears on the display. If the message "Charging completed" appears, although still charging and the charging phase is displayed, then the trickle charging phase has been started. The trickle charging is for battery charge maintenance and for some battery types for cell equalization.

## MECHANICAL INSTALLATION

The following things must be considered during the installation:

- 1. Ensure the distance from the walls or other objects**  
Ensure the distance from the walls or other objects. Leave enough space (at least 10 cm) between the cooling openings and other objects or walls, so that the air can circulate well.
- 2. Avoid the heat build-up**  
Despite very high efficiency quite a lot of heat arises. Therefore, the charger must only be installed in places with enough air exchange. Otherwise, the air temperature rises in the vicinity of the device and the charging current may be reduced or the device may turn off.
- 3. Horizontal mounting**

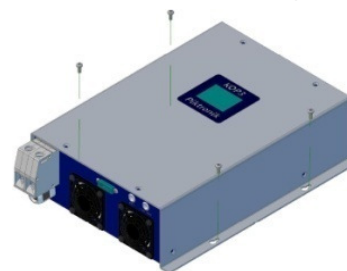

Mount the charger on a flat surface (from the top) as shown on the image. The device can withstand higher stress due to vibration and shock in a horizontal position.

- 4. Vertical mounting**



The cables and terminals must be on the lower side so that the fan moves the hot air up - as shown on the image.

**IMPORTANT:** The charger must be mounted vertically in applications such as electric vehicles, since high shock and vibrations are common in such applications and it can withstand better in such position.

**IMPORTANT:** Observe the additional warnings (see the table).  
Do not make any holes on the chassis, as components can be damaged.  
Mount the charger on a flat surface.

## CONNECTIONS and ACCESSORIES



Positions of Connectors

The charger will be delivered with 2 m long battery wires (25 mm<sup>2</sup> for the 24V version and 16 mm<sup>2</sup> for the 48V Version). Other lengths/versions on request.

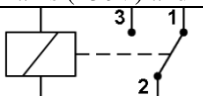
Name	Pin Functions
<b>PTC</b> Mini-XLR 3p	1 – GND 2 – Serial output (communication with KOP-USB or KOP-PROT) 3 – PTC (PTC for battery temperature measurement)
<b>CAN / BMS</b> Mini-XLR 5p	1 – BMS-IN Cathode of the optocoupler for the BMS PWM input (Anode connected to +12V through a 1k0 resistor) Current through the optocoupler diode min. 1 mA. 2 – +12V Power supply for the external display (max. 100 mA) 3 – GND2 Ground connection for the external display 4 – CAN-H Communication with the display or other devices 5 – CAN-L (no CAN Bus termination resistors in the charger) All signals and the 12V power supply are galvanically separated from the mains (230V) and from the battery.
<b>RELAY</b> Phoenix MSTBV	 <p>Contacts: max. 5A continuous/switching current The connector pin numbers counted from the left. Relay functions are programmable.</p>

### Accessories for KOP3 Chargers

Order code	Description
KOP-DIS1-6,0	External display with 6 m cable and 5p mini XLR plug The display shows the same information as the built-in display.
CKOP-T3,6	Battery temperature sensor with a 3 pin mini-XLR plug (3,6 m long) Other lengths and versions on request.
G00500003	Mini XLR plug – 3 pin version
G00500004	Mini XLR plug – 5 pin version
G00500059	Mating connector to the relay socket

## TROUBLESHOOTING

Display on the device does not turn on after connection to the mains socket	Check the mains connection. Check if the mains voltage is present
Charging does not start	Check the warning or the error message shown on the display. The list of possible errors is shown below.
Battery voltage is too low	The battery voltage is lower than the minimum value at which the charger is allowed to start.

Error number	Description
1	Charger temperature sensor or cooling fan failed
2	Charging time limit has been exceeded
3	Battery temperature sensor failed or not connected or shorted
4	Charger temperature during the charging process is too high
5	Battery voltage too high at the start of the charging
6	Battery temperature too low during charging
7	Battery temperature too high during charging
8	Charger disconnected from the battery during charging
9	Incorrect parameter checksum
10	Problems with the current measurement
11	Incorrect parameter values
12	Internal problem with the power measurement or no release signal from the power stage
13	The charging current measurement is outside of the tolerances or the is overloaded at very low output voltage
14	Problem with the current control

### Technical characteristics

Charger type	KOP3-24V	KOP3-48V
Nominal voltage / current	24V / 125A	48V / 62.5A
Typ. efficiency	91%	92%
Power factor	min. 95%, typ. 99% at 230V and full power	
Mains current	max. 15A (limited by charger firmware)	
Mains voltage	180 V - 264 V / 47 - 63 Hz	
Protection grade	IP20 (IP21 with horizontal mounting)	
Weight	6.3 kg (incl. 230V cable and plug)	
Dimensions (L x W x H)	380 x 265 x 95 mm	
Approvals	EN 55011 Class B, EN 60336-2-29 EN 61000-3-2/3-3/4-2/4-5/4-6/4-11/6-2/6-3	

## SAFETY INSTRUCTIONS

1. Read the manual thoroughly.
2. The charger must be used with the original cables only. Do not change, shorten, extend or short circuit the cables.
3. Remove the mains plug from the mains first before breaking the battery circuit.
4. Only rechargeable batteries can be used. Do not connect any non-rechargeable batteries (like dry-cell batteries) to the charger.
5. The charger may be used for the correct battery type only.
6. Do not install the charger inside motor-homes, campers or caravans.
7. Check the charger for cable, housing and connector damages before use. Do not operate the charger when damaged.
8. There are no user serviceable parts inside. Refer servicing to qualified service personnel.
9. Do not expose the charger to rain, moisture, direct sunlight or dust.
10. Always disconnect the mains after charging and generally when the device is not in use. During the trickle charge the charger remains attached to the mains.
11. Always disconnect the mains plug (230 V) during a thunderstorm.
12. Observe the warnings on the last page of this manual.

**NOTE:** The charger has a very low internal power consumption. Therefore, depending on the function, the display can remain switched on even over 20 seconds after disconnecting the power plug.

## WARNINGS

<b>COOLING</b>	Do not cover the charger housing and protect it from direct sunlight or other heat sources. The charging current is reduced at elevated ambient temperatures and the charging time increases accordingly. The built-in fan must be able to cool the electronics well. The fan speed depends on ambient temperature and charging current.
<b>CONNECTION</b>	Output currents are very high. Select the correct wire/cable size, use ferrules for wire ends, keep contact points clean and properly connect the output terminals.
<b>FUSES</b>	The fuse in the charger is not a sufficient protection for the battery cable from the battery to the charger. A corresponding fuse must be located in the immediate vicinity of the battery terminal.
<b>MAINS CONNECTION</b>	The line current is limited to 14.8 A by the charger firmware. Please check if the wall socket and the mains fuse meet this current.
<b>BATTERY TYPE / SIZE</b>	Use this charger for the pre-set battery type and size only, otherwise the battery may not be fully charged or the battery can be damaged or it's life can be reduced.
<b>LITHIUM BATTERIES</b>	Lithium batteries are very sensitive to overcharging and overheating. The charger can regulate only the total voltage, but can not recognize states of individual cells. Therefore, the charger should only be used together with a battery management system.
<b>LEAD-ACID BATTERY GASSES</b>	Lead-acid batteries produce hydrogen-oxygen gases, which can be explosive, and sulfuric acid that can cause severe burns. Make sure the working area is well-ventilated. Cigarettes or any open fires or sparks may cause an explosion. Keep all ignition sources away from the battery.
<b>ACIDS</b>	Battery acid can damage your eyes and skin. In the event of an accident, flush with water and seek medical help immediately. Use proper personal protective devices when handling a damaged or leaking battery. Treat the material used to clean up the battery acid spill as hazardous waste.
<b>TOXIC SUBSTANCES</b>	Batteries contain hazardous materials. Among others, lead and antimony are toxic substances. Waste lead-acid and many other battery types are hazardous waste and must be treated according to the Battery Disposal Regulations.

Producer:

**Piktronik d. o. o.  
Cesta k Tamu 17  
SI – 2000 Maribor**

Distributor: